



Simulation and analysis of a stand-alone solar-wind and pumped-storage hydropower plant



Fontina Petrakopoulou ^{a, b, *}, Alexander Robinson ^{c, d}, Maria Loizidou ^a

^a Unit of Environmental Science and Technology, National Technical University of Athens, 15773 Athens, Greece

^b Department of Thermal and Fluid Engineering, Universidad Carlos III de Madrid, Avda. de la Universidad 30, 28911 Leganés (Madrid), Spain

^c Department of Astrophysics and Atmospheric Sciences, Universidad Complutense de Madrid, 28040 Madrid, Spain

^d Instituto de Geociencias, UCM-CSIC, 28040 Madrid, Spain

ARTICLE INFO

Article history:

Received 29 August 2015

Received in revised form

24 November 2015

Accepted 14 December 2015

Available online xxx

Keywords:

Hybrid power plant

Renewable energy

Energy autonomy

Off-grid operation

Dynamic simulation

ABSTRACT

This work presents the simulation and evaluation of a renewable hybrid power plant for off-grid fully autonomous operation on an intermediate-sized island in the Aegean Sea. A stand-alone energy system including storage facilities is simulated, optimized and analyzed relying on real-case weather and demand data of a relatively large remote community. Optimization of the power plant structure shows that to ensure continuous off-grid energy generation, even under extreme conditions, the combination of more than one renewable technology is required. The hybrid power plant consists of a pumped-storage hydropower plant, photovoltaic cells and wind turbines. Energy surplus of the power plant is used in the incorporated electrolyzer to generate a secondary product, hydrogen. Robust operation of the plant results in 48% of the energy generated stemming from the photovoltaic system and 52% from the wind turbines. The pumped-storage hydropower plant has a mean annual power output of 1.0 MW. The total mean annual efficiency of the hybrid plant is found to be 14.4%. Although stand-alone operation was achieved with the proposed plant, this requirement led to net energy output restrictions, capacity oversizing and large storage facilities.

© 2015 Elsevier Ltd. All rights reserved.

1. Introduction

Robust and efficient electricity generation on islands and remote regions is an issue of significant interest, especially in countries heavily reliant on fossil resources. Renewable power plants can offer an environmentally and economically sustainable alternative to conventional energy sources that may currently exist in such areas [1–4]. In addition, renewable hybrid plants establish a more competitive environment for RES (renewable energy sources) [1,5,6] taking advantage of the benefits of individual technologies and allowing their complementary coupling [7]. This paper presents the simulation and thermodynamic evaluation of a renewable hybrid power plant for stand-alone operation on an island in Greece.

Greece has 6000 islands and islets scattered in the Aegean and Ionian Seas, from which 227 islands are inhabited [8]. The

minimum target of Greece for RES contribution by 2020 is 18% with 40% of this share stemming from electricity generation. The islands present a challenge to develop a unified energy development policy due to their unique characteristics. Additionally, geomorphological particularities offer highly diversified topography and geo-characteristics of the islands, unparalleled landscape, volcanic soil and fascinating local traits.

Non-interconnected islands are islands not yet connected with the electrical system of the mainland, mainly due to logistical, technological and financial difficulties. On the non-interconnected islands, the main priority of the country's strategy is the installation of RES plants, including hybrid RES plants and offshore wind parks. These plants will operate either as autonomous systems or they will be connected to the existing interconnected system as additional energy resources. In the electricity sector it is expected that lignite and petroleum will gradually give way to mainly natural gas and wind power.

In recent years various efforts towards energy self-sufficiency with renewable technologies have been noted and ever more examples of regions that have managed to achieve or orientate themselves towards that goal are arising [9,10]. However, although the use of renewable resources is increasing, it is mainly the result

* Corresponding author. Department of Thermal and Fluid Engineering, Universidad Carlos III de Madrid, Avda. de la Universidad 30, 28911 Leganés, Madrid, Spain.

E-mail address: fpetrako@ing.uc3m.es (F. Petrakopoulou).

of isolated activities and less of fully organized movements, while total energy independence without the support of a centralized electrical grid is yet to be achieved.

This work presents results of the project GENERGIS (European project entitled: Green Energy for Islands) related to the energy autonomy of isolated areas, specifically of islands [11]. A novel aspect of the project was to include energy storage technologies in original hybrid power plants, to cover demand when renewable resources weren't available. This holistic view of the project was necessary for assuring complete energy independence in remote regions. For the purpose of the project, one medium-sized non-interconnected island was studied and energy strategies towards its 100% renewable energy autonomy were proposed. GENERGIS constituted the first complete study of stand-alone renewable energy power plants for the energy autonomy of a community of approximately 3000 people.

According to the Greek RAE (regulatory authority for energy), most of the islands in Greece today (mainly in the Aegean Sea) are electrified by autonomous electrical systems generating electricity primarily using local thermal power plants that operate with heavy (mazut) or light (diesel) oil and RES stations (wind and photovoltaic) [12]. The small and medium-scale autonomous islands in the Aegean Sea represent approximately 10% of the country's total energy consumption [13]. The electricity market of the non-interconnected islands consists of 32 autonomous systems. Some of them consist of several islands (clusters of islands).

The demand (consumption in MWh) of electricity on the non-interconnected islands varies from several hundred MWh in the smaller islands (e.g., Antikythera, Agathonisi, etc.), up to several TWh in the biggest non-interconnected island (Crete). According to the Hellenic Electricity Distribution Network Operator (HEDNO/DEDDIE), in December 2014 84% of the energy generation on non-interconnected islands came from thermal power plants, 13% from wind parks and 3% from PV (photovoltaic) stations. Most of the wind and PV stations have been installed by far on the island of Crete, followed by the island of Rhodes. The contribution of RES stations to the electricity generation on the non-interconnected islands in December 2014 was 15.6% [14].

1.1. Presentation of the case study

The island of Skyros in the Aegean Sea was chosen as the case study of the project GENERGIS based on specified quantitative and

qualitative criteria [11]. Skyros belongs to the prefecture of Evvoia and the region of Central Greece. The island is situated in the most southern part of the northern Sporades in the Aegean Sea and it is the biggest island (208,594 km²) in the group of Sporades [15]. According to the census of 2011, Skyros had 2994 permanent residents (increased from 2711 in 2001 [16]) with 1638 men and 1356 women [17]. The low population density of the island reveals good potential for developing applications with RES, however it should be noted that environmental and property restrictions limit the available land that can be accounted for in energy development plans. The current electricity energy needs of Skyros are covered through the combustion of diesel oil. Electricity is currently used to cover part of the space and water heating needs of the island, as well as operate lighting and electrical and cooling appliances.

Based on information provided by the Hellenic National Meteorological Service, Skyros enjoys approximately 2500 h of sunshine annually [18]. Satellite-based data on the global irradiation on an optimally-inclined surface for Skyros are shown in Map 1 and for a larger area in Greece in Map 2. The data were provided by the Institute for Energy and Transport of the Joint Research Centre of the European Commission (CMSAF data set) [19] and their visual representation was realized using the open-source software QGIS [20].

As seen in Map 2, the solar potential of Skyros is very high in comparison to other areas in mainland Greece, approaching that of islands in the southern part of the country. Skyros also has great exploitable wind energy potential (see Fig. 1). Higher wind speeds surpassing 10 m/s are observed in the southern part of the island. Map 3 shows daily wind speed measurements from one station on Skyros and Map 4 the wind potential for a larger area of Greece [21]. In order to calculate energy generation using the variation of wind speed, specific technological characteristics of the utilized wind turbines must be used.

The significant potential for Skyros to export wind energy to the mainland to increase national renewable energy generation has been reported numerous times in various reports. Although various large-scale wind farm projects have been proposed for construction on the island, they face social opposition. The present work proposes the installation of a power plant for energy autonomy on the island, i.e., a facility that will exclusively cover the current and future energy needs of the island.

The future electric energy demand of Skyros, as anticipated by the DEDDIE in 2012, is shown in Table 1 [22]. Assuming an

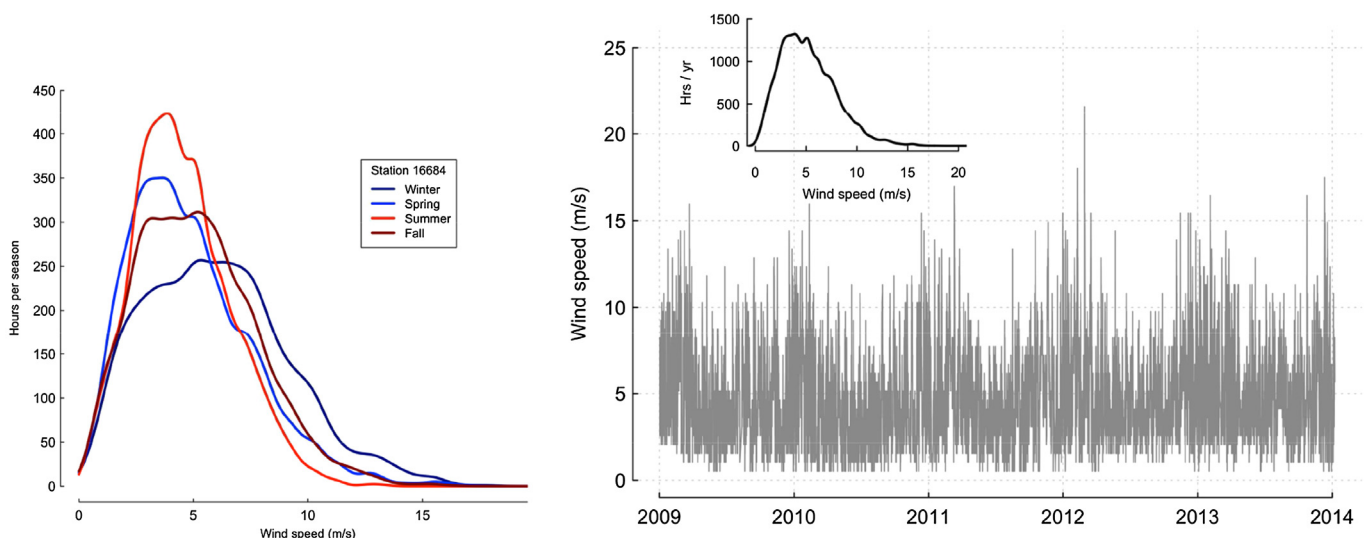

Fig. 1. Seasonal and daily variation of wind speed for the years 2009–2013.

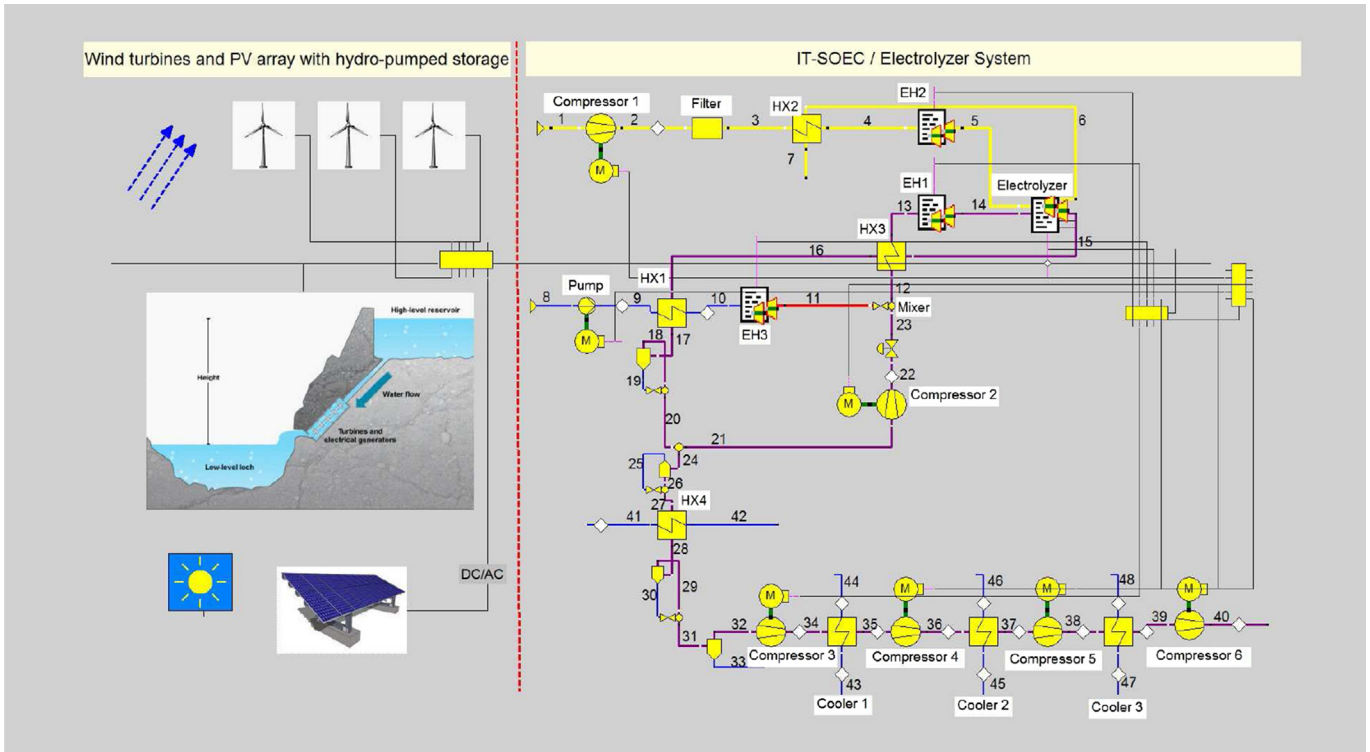

Fig. 2. Simulation flow diagram of the PV-wind plant with pumped-storage hydropower. Image of hydro-pumped power plant from: <http://pixshark.com/hydroelectric-power-plant-diagram.htm>

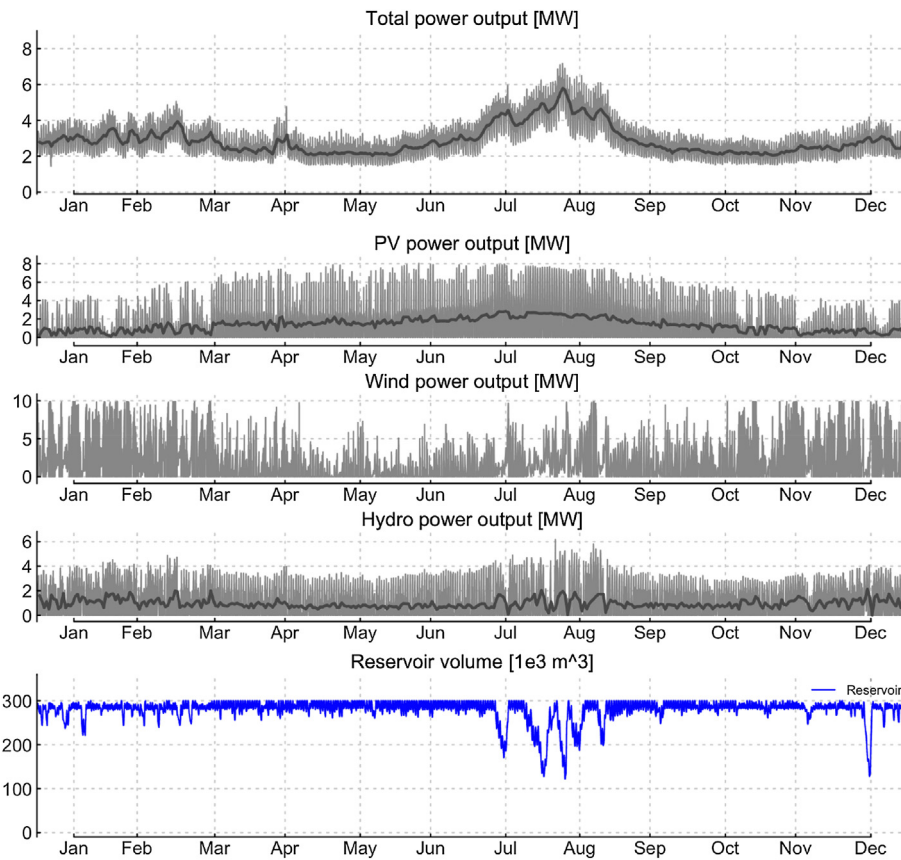
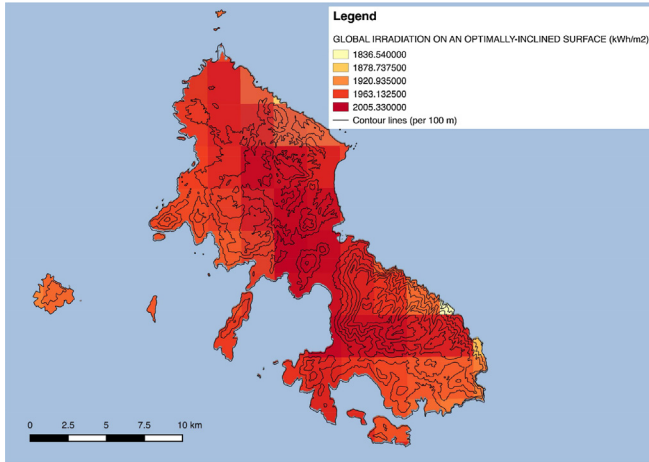
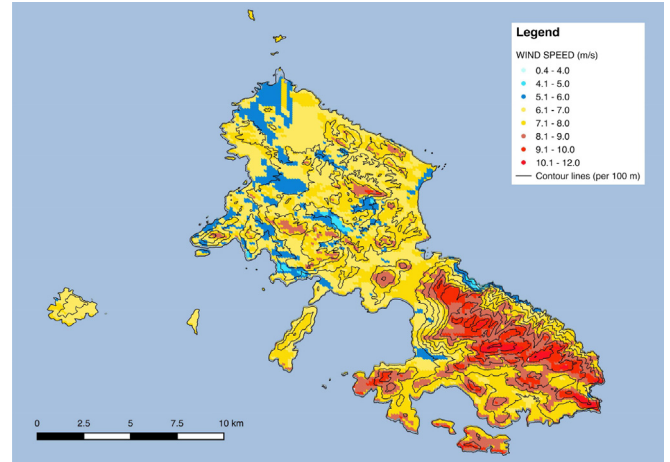

Fig. 3. Performance of the PV-wind-hydro pumped storage power plant (daily mean shown by thick darker lines).



Map 1. Yearly sum of global irradiation on optimally-inclined surface on Skyros (kWh/m²) – Satellite-based solar radiation data – Period 1998–2011 [19].



Map 3. Wind speed on Skyros.

approximate annual energy increase of 1.4%, the energy demand of the island is further projected to selected years of importance for the present paper.

1.2. Methodology

To evaluate the proposed power plant an exergetic analysis was used, the principles of which are well known [23–25]. To realize an exergetic analysis the operation of each component constituting the plant must be evaluated. This is facilitated through the definition of the exergy of the fuel and product ($\dot{E}_{F,k}$ and $\dot{E}_{P,k}$) of each plant component. The fuel of a component represents the resources that must be used to generate the product, while the product is the result itself. The ratio of the exergy of the product to the exergy of the fuel is the exergetic efficiency, ε_k , of the component, which demonstrates its thermodynamic performance. The difference between the exergy of the fuel and product represents the exergy destruction within the component ($\dot{E}_{D,k} = \dot{E}_{F,k} - \dot{E}_{P,k}$), while at the system-level it represents the sum of exergy destruction and exergy loss of the overall system ($\dot{E}_{D,tot} + \dot{E}_{L,tot} = \dot{E}_{F,tot} - \dot{E}_{P,tot}$).

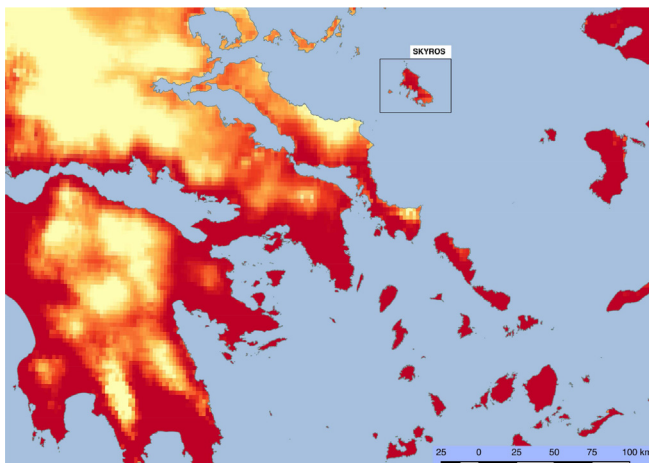

Map 2. Yearly sum of global irradiation on optimally-inclined surface for a larger area of Greece (kWh/m²) – Satellite-based solar radiation data – Period 1998–2011 [19].

The exergy of solar power (exergy of the fuel of the solar field or PV array) is calculated as [26]:

$$\dot{E}_{sun} = \dot{Q} \cdot \Psi_s$$

where, \dot{Q} is the solar irradiation available from the sun (global horizontal irradiation, GHI , in the case of PV plants). Ψ_s is the ratio between exergy and energy calculated as:

$$\Psi_s = \left[1 - \frac{4}{3} \left(\frac{T_a}{T_s} \right) + \frac{1}{3} \left(\frac{T_a}{T_s} \right)^4 \right]$$

where, T_a is the ambient temperature and T_s is the apparent black body temperature of the sun (5600 K).

The input exergy of wind, that is also the exergy of the fuel of the wind turbines, is the kinetic power of the wind calculated as:

$$\dot{E}_{wind} = \frac{1}{2} \cdot m \cdot v^2 = \frac{1}{2} \cdot \rho \cdot A \cdot v^3$$

where, m is the mass flow rate of the air going through the wind turbine's swept area, ρ is the density of the air (1.23 kg/m³), A is the total swept area of the wind turbines and v is the wind speed.

Finally, the water exergy received by the hydropower plant, that is the exergy of the fuel of the turbine of the plant, is the dynamic energy of the water at the height of the upper reservoir (equal to its kinetic energy at the lower reservoir):

$$\dot{E}_{hydro} = h \cdot \rho \cdot g \cdot \dot{v}$$

where, h is the height between the upper and lower reservoirs, ρ is the water density (1000 kg/m³), g is the gravitational constant (9.81 m/s²) and \dot{v} is the volumetric flow rate of water.

To calculate the physical and chemical exergies of the material streams the software THESIS, originally developed at the RWTH Aachen [27], has been used. The component-level analysis was then realized using the open-source software Python.

1.3. Simulation of the power plant

The hybrid power plant proposed in this paper combines PV and wind with a pumped-storage hydropower plant. This suggestion is similar to a proposal presented by the municipality of Skyros for the combination of a pumped-storage hydropower plant with wind turbines to store and generate energy. The case presented here

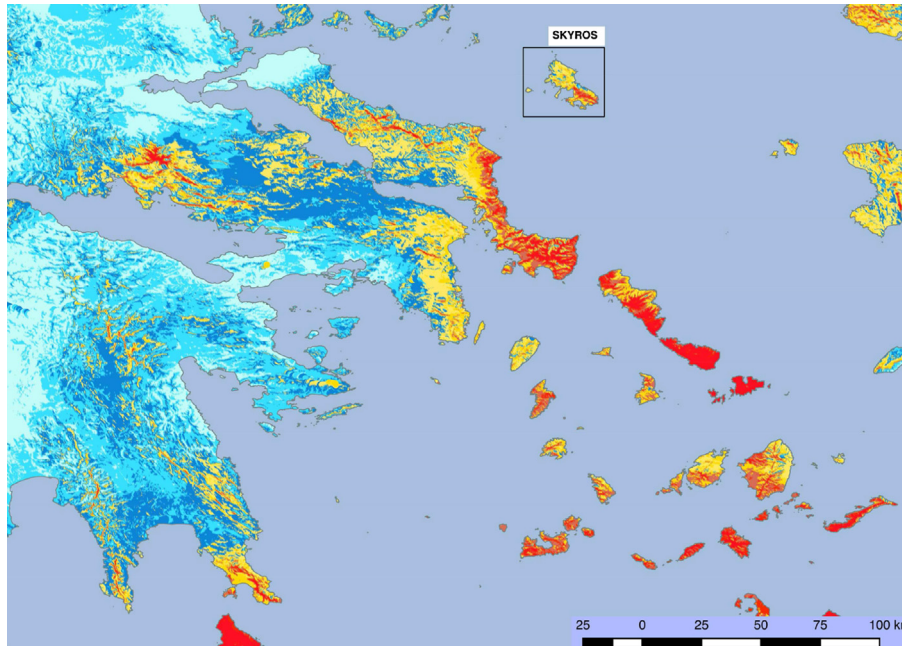

Map 4. Wind speed in a larger area of Greece.

includes solar energy and it is designed and optimized for stand-alone system operation for continuous and complete coverage of the energy demand as projected to the last year of the economic life of the power plant (2045). The plant is assumed to start operation in 2020 and have an economic life of 25 years. The 2012 hourly time series of electricity demand on Skyros was extrapolated to 2045 with an annual energy increase of 1.4% [22].

When the solar irradiation levels are adequately high, the energy demand is satisfied by the operation of the PV plant. If, on the other hand, there is solar deficit, the wind turbines are used to supplement the energy requirement of the island. The hydropower plant is used when the energy demand cannot be covered by the combination of PV and wind plants. When there is a surplus from the PV or wind systems, the operation of the hydro plant is reversed to pump water to the upper reservoir, as needed. Any additional surplus generated by the plant is sent to the electrolyzer unit of the plant to generate H_2 .

For the construction of the hydropower plant, the water dam constructed in the area of Ferekampos of Skyros (expected to start operation by the end of 2015) is used as the lower reservoir. The capacity of this reservoir is 1,000,000 m^3 and it is located at an altitude of approximately 80 m. The upper reservoir (proposed) is

situated northwest of the existing reservoir at a height of approximately 380 m (see Map 5) and has a capacity of 300,000 m^3 . The two reservoirs will be connected with pipes of 1500 m length.

The electromechanical equipment of the hydropower plant includes a pump-turbine, a generator/motor, a transformer and cabling and control systems. The turbine included in the hydropower plant is a Francis pump-turbine with reversible operation and a variable-speed motor/generator. The variable operation of the hydropower plant offers the possibility to regulate its power output and pumping power requirement based on the needs and electricity availability of the hybrid plant.

The power generated by the turbine of the hydropower plant is calculated as:

$$\dot{W}_{HPP} = h \cdot \rho \cdot g \cdot \eta_T \cdot \eta_{el} \cdot \dot{v}$$

where, h is the head (difference in elevation between the upper and lower reservoir (300 m), ρ is the density of water (1000 kg/m^3), g is the gravitational constant (9.81 m/s^2), η_T is the efficiency of the pump-turbine (85%), η_{el} is the efficiency of the generator/motor (95%) and \dot{v} is the volumetric flow of water (m^3/s) that depends on the energy demand.

The flow diagram of the hybrid power plant is shown in Fig. 2 and its operating conditions and characteristics in Table 2. The sizes of the PV system and wind turbines are optimized for maximizing power coverage. The PV array is designed with a maximum power output of 10.5 MW. The panels used in the simulation are monocrystalline silicon panels based on the model EP156M/60-250W of the company Eoply New Energy Technology Co., Ltd. Each panel includes 60 cells, has a peak efficiency of 15.3% and generates 153.0 W/m^2 under standard test conditions [28].

The simulation of the wind turbines assumes wind turbines of the type Vestas V112–3.3 MWTM IEC IB with given power curve. Each wind turbine has rated power output of 3.3 MW, a hub height of 84 m, a rotor diameter of 112 m with swept area 9852 m^2 and cut-in and cut-out speeds of 3 and 25 m/s.

The electrolyzer of the plant is an intermediate-temperature solid-oxide electrolysis cell [29,30]. The electrolyzer uses

Table 1
Projected energy demand on Skyros.

Year	Total energy demand [MWh]	Peak demand [MW]
2013	15,531	4.668
2014	15,918	4.737
2015	16,055	4.807
2016	16,207	4.876
2017	16,369	4.946
2018	- ^a	5.015
2019 ^b	16,698	5.085
2020 ^b	16,865	5.156
2045 ^b	21,628	7.300

^a Missing value from the data set provided by DEDDIE.

^b Data projected using an annual energy increase of 1.4%.

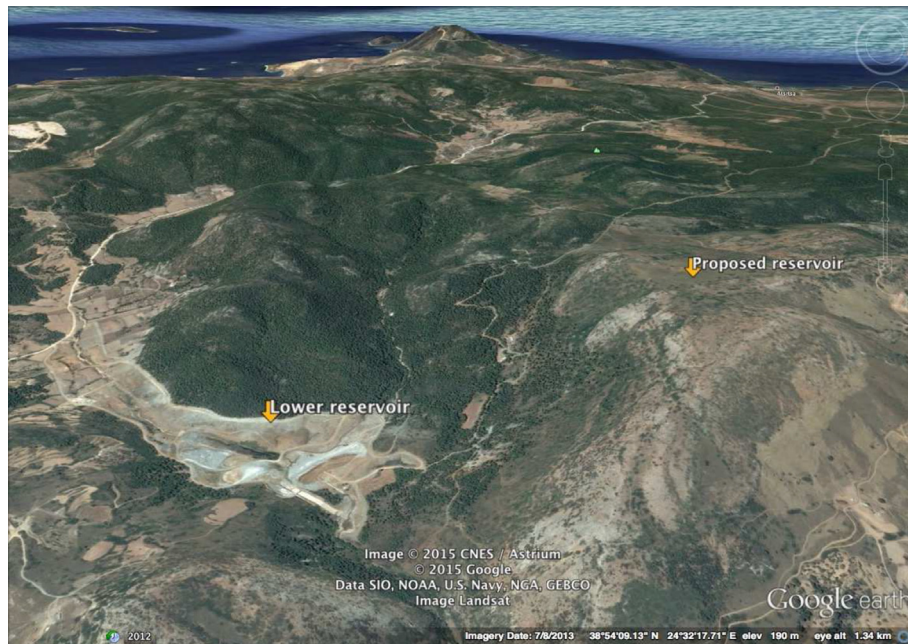

Map 5. Map of upper and lower reservoirs.

Table 2
Operating conditions of the hybrid power plant.

Photovoltaic	
<i>Panels</i>	
Model [-]	EP156M/60–250 MW
Material [-]	Monocrystalline silicon
No. of cells [-]	60
Peak efficiency [%]	15.3
Generation (STC) [W/m ²]	153,0
<i>PV plant</i>	
Power output [MW]	10.5
Efficiency [%]	12.5
Wind turbines	
Model [-]	Vestas V112 (IEC IB/IEC S)
Rated power [MW]	3.3
Efficiency [%]	
Hub height [m]	84
Rotor diameter [m]	112
Swept area [m ²]	9852
Cut-in speed [m/s]	3
Cut-out speed [m/s]	25
Hydropower plant	
<i>Upper reservoir</i>	
Capacity [m ³]	300,000
Height [m]	380
<i>Lower reservoir</i>	
Capacity [m ³]	1,000,000
Height [m]	80
<i>Pipeline</i>	
Length [m]	1500
<i>Turbine/pump</i>	
Type [-]	Francis – variable volumetric water flow
Efficiency [%]	85 ^a
<i>Generator/motor</i>	
Efficiency [%]	95
Electrolyzer unit	
<i>Electrolyzer</i>	
Operating temperature [°C]	700
Steam conversion rate [%]	61
Sweep gas/cathode stream ratio [-]	1:1
Cathode inlet [v/v]	H ₂ : 10; H ₂ O: 90
Cathode outlet [v/v]	H ₂ : 65; H ₂ O: 35
Hydrogen generated [v/v]	H ₂ : 90.5; H ₂ O: 9.5

^a It includes the exergy destruction due to fluid friction in the piping of the hydroelectric system.

electricity to convert any electricity surplus into hydrogen through water electrolysis. The electrolysis cells work at thermoneutral voltage, at a temperature of 700 °C, with a steam conversion rate in the cathode chamber of 61% and a molar ratio between the anode and cathode of 1:1. The generated hydrogen is finally compressed to 150 bar and stored [31].

1.4. Evaluation of the power plant

The performance of the power plant is presented in Fig. 3. Because the electricity generation by the PV panels is relatively low in the winter season, the operation of the PV array must be supplemented by the wind turbines. Surplus solar and wind energy is used to pump water to the upper reservoir, when this is required. In periods with high energy demand (summer) or relatively low solar irradiation and wind (winter), the energy demand is supplemented by the hydropower plant.

The maximum and mean efficiency of the PV array is 12.5%, while the maximum efficiency of the wind plant reaches the 45.7%. The average capacity factors of the PV and wind plants are found to be 16.1 and 15.2%, respectively. 48% of the total energy generated from the hybrid plant stems from the PV system and 52% from the wind turbines. The generated energy surplus of the hybrid plant (2832 MWh/a from the operation of the PV array) is sent to the electrolyzer of the plant to generate hydrogen. The maximum capacity of the electrolyzer is 5.8 MW, while the annual generated hydrogen is 95 tonnes.

Although approximately 1/3 of the total power of the hybrid plant is generated by the hydropower plant, the hydropower facility is considered a storage facility, since its dynamic condition and operation depend on the operation of the two main incorporated technologies, solar and wind. The pumped-storage hydropower plant reaches 6.2 MW power output when operating at full load and has a mean annual operation of 1.0 MW. The round-trip efficiency of the pump-turbine is 72.3%, while the efficiency of the electrical motor/generator is 90.2%.

The electrolyzer requires 5.8 MW at full load and generates 0.06 kg/s of hydrogen with an exergy output of 3.9 MW. The results

of the exergetic analysis of the individual components in the electrolyzer unit are presented in Table 3.

As seen in Table 3, the exergetic efficiency of the electrolyzer unit is 66.7%. The highest contribution to the total irreversibilities stems from the operation of EH3, followed by the inter-cooled H₂ compressor unit and the electrolyzer. Accounting for mean annual operation conditions (322 kW), the electrolyzer generates 0.003 kg/s of hydrogen resulting in an exergy output of 0.2 MW. The overall exergetic efficiency of the unit is found to be 66.8%.

The overall exergetic efficiency of the plant is calculated using the mean annual exergy values shown in Table 4. The denominator of the efficiency equation shown below represents the exergy input to the power plant necessary to generate the desired product, while the numerator represents the generated product. The overall annual mean efficiency of the hybrid plant is calculated as:

$$\begin{aligned} \varepsilon_{\text{mean,hybrid}} &= \frac{\dot{E}_{P,\text{hybrid}}}{\dot{E}_{F,\text{hybrid}}} \\ &= \frac{\dot{E}_{P,\text{PV,mean}} + \dot{E}_{P,\text{wind,mean}} + \dot{E}_{P,\text{electrolyzer,mean}}}{\dot{E}_{F,\text{sun,mean}} + \dot{E}_{F,\text{wind,mean}}} \end{aligned}$$

with $\dot{E}_{F,\text{sun,mean}}$ the mean annual solar exergy received from the sun calculated with the mean value of GHI, $\dot{E}_{F,\text{wind,mean}}$ the mean exergy of the fuel of the wind, $\dot{E}_{P,\text{electrolyzer,mean}}$ the mean annual exergy of the product of the electrolyzer (exergy of generated hydrogen), $\dot{E}_{P,\text{PV,mean}}$ the net mean annual exergy of the product of the CSP plant and $\dot{E}_{P,\text{wind,mean}}$ the net mean exergy of the product of the wind turbines.

The total annual mean efficiency of the hybrid PV-wind plant with hydro-pumped storage is found to be 14.4%.

The proposed hybrid plant operates autonomously and would provide energy independence to the island of Skyros. It covers the current and future annual energy demand of up to 21,628 MWh. Thus, the hybrid plant wholly eliminates the need for the community to import oil to the island, which it currently does at the rate of 3.5 tons per year. It provides the additional benefit of turning the island into an energy producer through the export of hydrogen generated in the plant. These factors make the hybrid plant an attractive option for future energy development on the island.

Table 3
Results of the exergetic analysis of the electrolyzer unit at the component level.

	\dot{E}_F [MW]	\dot{E}_P [MW]	\dot{E}_D [MW]	ε [%]
EH1	0.08	0.05	0.03	68.3
EH2	0.02	0.01	0.01	67.8
EH3	1.07	0.24	0.83	22.7
HX1	0.04	0.01	0.03	35.0
HX2	0.33	0.27	0.05	83.5
HX3	0.43	0.24	0.19	56.0
HX4	0.04	0.03	0.01	85.5
Electrolyzer	3.81	3.49	0.31	91.8
Compressor 1	0.01	0.00	0.01	32.5
Compressor 2	0.01	0.00	0.00	31.8
Compressor 3	0.19	0.12	0.07	62.9
Compressor 4	0.21	0.12	0.09	58.0
Compressor 5	0.17	0.09	0.08	52.2
Compressor 6	0.22	0.13	0.09	57.8
Cooler1	0.08	0.01	0.07	9.7
Cooler2	0.07	0.01	0.07	10.3
Cooler3	0.05	0.01	0.04	12.1
Mixer	0.60	0.59	0.02	97.4
Total	5.79	3.87	1.84	66.8
$\varepsilon_{L,\text{tot}} = 0.08$				

Table 4
Calculated exergy values at full-load and mean annual operation of individual RES technologies.

	\dot{E}_F [MW]	\dot{E}_P [MW]	\dot{E}_D [MW]	ε [%]
PV plant				
Full load	65.7	8.2	57.5	12.5
Mean annual	13.5	1.7	11.8	12.5
Wind farm				
Full load	31.4	9.9	21.5	31.5
Mean annual	10.1	1.5	8.6	14.9
Hydrogen storage				
Full load	8.1	5.4	2.7	66.7
Mean annual	0.8	0.5	0.3	66.7
Hydro-pumped storage				
Full load	7.6	6.2	1.5	80.8
Mean annual	1.2	1.0	0.2	80.8

Within the framework of the project GENERGIS two alternatives for the 100% renewable energy autonomy of the island of Skyros were examined. The first option included a concentrating solar power plant with thermal storage and wind turbines coupled with electricity storage, while the second choice included photovoltaic panels, wind turbines coupled with electricity storage and an electrolyzer for hydrogen generation. The power plants were evaluated based on their exergetic performance and the associated economic expenditures. When comparing the plant presented here with the two other alternatives, it is seen that this plant results in the worst exergetic efficiency and the largest land requirement. Nevertheless, the economic analysis reveals this plant as the second best choice due to the relatively higher generation of hydrogen that lowers the overall cost of electricity.

2. Conclusions

This paper presented the simulation and thermodynamic evaluation of a hybrid power plant for stand-alone operation on the island of Skyros in Greece. The hybrid power plant included photovoltaic cells, wind turbines and a pumped-storage hydro-power plant. Energy surplus was sent to an electrolyzer unit coupled to the power plant in order to generate additional hydrogen.

The electricity generation from the photovoltaic array of the hybrid plant was found to be relatively low in the winter season and its operation was supplemented by the wind turbines. When required, surplus solar and wind energy were used to pump water to the upper reservoir of the hydropower plant. Additional energy surplus from the operation of the photovoltaic array (2832 MWh/a) was sent to the electrolyzer of the plant. The hydrogen generated annually reached 95 tonnes.

48% of the total energy generated from the hybrid plant stemmed from the photovoltaic system and 52% from the wind turbines. The pumped-storage hydropower plant reached power output of 6.2 MW when operating at full load and had a mean annual operation of 1.0 MW. The total annual mean efficiency of the hybrid photovoltaic-wind plant with hydro-pumped storage was found to be 14.4%.

The renewable hybrid plant presented in this paper was designed based on stand-alone requirements for off-grid operation. The simulation and evaluation of the plant confirmed that in order for a renewable plant to offer stability and secure energy generation, more than one renewable technology must be combined. The assumption of stand-alone operation led to net energy output restrictions, capacity oversizing and large storage facilities. In an alternative case, where the island is connected to the mainland grid

and the energy power output of the plant is limited to exclusively serve the energy demand of the island, energy residuals are avoided and the capacity factor of the plant increases significantly.

Acknowledgments

Fontina Petrakopoulou would like to thank the Universidad Carlos III de Madrid, the European Union's Seventh Framework Programme for research, technological development and demonstration (grant agreements n° 600371 and 332028), the Ministerio de Economía y Competitividad (COFUND2014-51509) and Banco Santander.

References

- [1] Bhandari B, Lee K-T, Lee CS, Song C-K, Maskey RK, Ahn S-H. A novel off-grid hybrid power system comprised of solar photovoltaic, wind, and hydro energy sources. *Appl Energy* 2014;133:236–42.
- [2] Bajpai P, Dash V. Hybrid renewable energy systems for power generation in stand-alone applications: a review. *Renew Sustain Energy Rev* 2012;16:2926–39.
- [3] Bianchi M, Branchini L, Ferrari C, Melino F. Optimal sizing of grid-independent hybrid photovoltaic–battery power systems for household sector. *Appl Energy* 2014;11–12.
- [4] Nixon JD, Dey PK, Davies PA. The feasibility of hybrid solar–biomass power plants in India. *Energy* 2012;46:541–54.
- [5] Mezzai N, Rekioua D, Rekioua T, Mohammedi A, Idjdarane K, Bacha S. Modeling of hybrid photovoltaic/wind/fuel cells power system. *Int J Hydrogen Energy* 2014;39(27):15158–68.
- [6] Peterseim JH, White S, Tadros A, Hellwig U. Concentrating solar power hybrid plants – enabling cost effective synergies. *Renew Energy* 2014;67:178–85.
- [7] Bernardos E, López I, Rodríguez J, Abánades A. Assessing the potential of hybrid fossil–solar thermal plants for energy policy making: Brayton cycles. *Energy Policy* 2013;62:99–106.
- [8] Greek National Tourism Organization (GNTO). Greek islands, http://www.visitgreece.gr/en/greek_islands, 2014.
- [9] The republic of Lithuania. Energy Independence – Common goal of the Baltics. 2012.
- [10] European Commission. Renewable energy for Europe. 2014. 100% Renew Energy Communities.
- [11] Petrakopoulou F. GENERGIS (Green energy for islands) 2012-IEF-332028. IEF Project supported by FP7. 2015.
- [12] RAE. Non-interconnected islands [available in Greek]. 2015. http://www.rae.gr/site/categories_new/electricity/market/mdn.csp.
- [13] ADMIE. Ten-Year Development Plan of the Transmission System 2015-2024 (Preliminary Plan) – (available in Greek). 2014.
- [14] DEDDIE. Monthly press releases of RES and Thermal generation in non-interconnected islands (available in greek). 2014.
- [15] DAFNE. Sustainable energy action plan for the municipality of skyros under the “Covenant of Mayors.” [available in Greek]. 2010.
- [16] Hellenic Statistical Authority -ELSTAT. Digital library (ELSTAT). 2009.
- [17] ELSTAT. Interactive map – population and residential census 2011: data of permanent population. 2014.
- [18] Hellenic National Meteorological Service. Personal communication HNMS-Sunshine hours of skyros. 2013.
- [19] Joint Research Centre (JRC). Satellite based solar radiation data. 2014.
- [20] QGIS. A free and open source geographic information system. 2014. <http://www.qgis.org/en/site>.
- [21] Hellenic National Meteorological Service. Personal communication. 2014.
- [22] DEDDIE - Island Management Division. Personal communication. 2013.
- [23] Tsatsaronis G, Czesla F. Energetic and exergetic analysis of complex systems. In: Frangopoulos Christos A, editor. Exergy, energy system analysis and optimization, vol. 3. EOLSS Publishers Company Limited; 2004.
- [24] Tsatsaronis G, Czesla F. Thermoeconomics. *Encycl. Phys. Sci. Technol. Academic Press*; 2002. p. 659–80.
- [25] Bejan A, Tsatsaronis G, Moran M. Thermal design and optimization. Wiley-Interscience; 1995.
- [26] Petela R. Exergy of undiluted thermal radiation. *Sol Energy* 2003;74:469–88.
- [27] Eisermann W, Hasberg W, Tsatsaronis G. THESIS – Ein Rechnerprogramm zur Simulation und Entwicklung von Energieumwandlungsanlagen. *Brennst Wärme Kraft* 1984;36:45–51.
- [28] SolarDesignTool. Eopply new energy EP156M/60-250W (250W) solar panel. 2015.
- [29] Petrakopoulou F, Sanz-Bermejo J, Dufour J, Romero M. Exergetic analysis of hybrid power plants with biomass and photovoltaics coupled with a Solid-oxide electrolysis system. *Energy* 2016;94:304–15.
- [30] Bucheli O, Lefebvre-Joud F, Petipas F, Roeb M, Romero M. Advanced electrolyzers for hydrogen production with renewable energy sources. In: Proc. 10th Eur. SOFC Forum, Lucerne; 2012. A1107.
- [31] Kroposki B. Distributed energy systems integration group – NREL. 2009.